

# MB3

The AKG/Crown® MB3 is a miniature boundary microphone for multi-miking applications such as teleconferencing, distance learning, boardrooms, courtrooms, and security applications. This low-profile, circular mic permanently installs into a hole drilled in a table, lectern, or ceiling.

Thanks to its supercardioid pickup pattern, the MB 3 greatly reduces ambient noise and pickup of room reverberation. The result is a clearer, more intelligible sound.

On the bottom of the mic is a tubular power module with a 3-pin XLR-type output connector. It is powered by 12-48V phantom power, and has a low-impedance balanced mic-level output.

## Features

- Small, inconspicuous.
- Installs permanently in table top, wall or ceiling.
- Clean, clear, natural sound.
- Low-Z balanced mic-level output prevents hum and high-frequency loss.
- Removable grille assembly can be painted.

## How to Paint the Microphone

1. Using a small screwdriver, pry open one side of the base, then the other side (Fig. 5).
2. Remove the foam liner.
3. Wearing a dust mask, spray-paint the grille assembly. Be sure grille holes are not clogged.
4. Allow to completely dry.
5. Make sure the LED is properly aligned.
6. Carefully place the grille assembly over the base, and snap in place.

## Installation

**Tables:** In a table, typical placement for each mic is an arm's length from the user. Install one microphone in front of each person, or one between every two people.

**Lecterns:** If the microphone will be used on a lectern, install it on an open surface. Do not install in a cavity or recessed area as the frequency response and polar pattern will be degraded.

**Ceilings:** When mounting mics in the ceiling, use as few mics as possible, and put them in front of the people speaking—not directly overhead.

**Note:** The system gain-before-feedback may not be adequate in ceiling mount applications because the mic is far from its user.

## MINI-BOUNDARY™ MICROPHONE



## Specifications

**Type:** Phase Coherent Cardioid.

**Element:** Electret condenser.

**Frequency response (typical):** 50 Hz to 15,000 Hz at 30 degrees incidence to surface (see Fig. 1).

**Polar pattern:** Half-supercardioid (supercardioid in the hemisphere above the primary boundary).  
See Figs. 2 and 3.

**Impedance:** 150 ohms, balanced (recommended load impedance 1000 ohms or greater).

**Open-circuit sensitivity (typical):**  
22 mV/Pa\* (-33 dB re 1 volt/Pa).

**Power sensitivity:** -30.5 dB re 1 mW/Pa\*.  
EIA rating: -125 dBm.

**Equivalent noise level (self-noise):** 22 dB SPL typical (0 dB=0.0002 dyne/cm<sup>2</sup>), A-weighted.

**S/N ratio:** 72 dB at 94 dB SPL.

**Maximum SPL:** 120 dB SPL at 3% THD.

**Polarity:** Positive (inward) pressure on the diaphragm produces positive voltage on pin 2 with respect to pin 3.

**Operating voltage:** Phantom power, 12-48 volts DC on pins 2 and 3 with respect to pin 1 of output connector.

**Current drain:** 4 mA nominal.

**Connector:** 3-pin pro audio, XLR-M type.

**Cable:** None supplied. Use two-conductor shielded mic cable.

**Materials:** High-impact molded plastic and steel mesh mic grille, steel chassis.

**Finish:** Satin black.

**Net weight:** 2.7 ounces (78 grams).

**Dimensions:** See Fig. 4.

**Optional accessories:** PH1A phantom power supply (1 channel, battery or DC-adaptor powered). PH4A phantom power supply (4 channels, AC powered).

\*1 pascal = 10 dynes/cm<sup>2</sup> = 10 microbars = 94 dB SPL.

Fig. 1

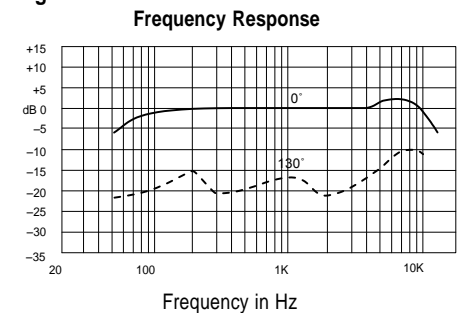

Fig. 2

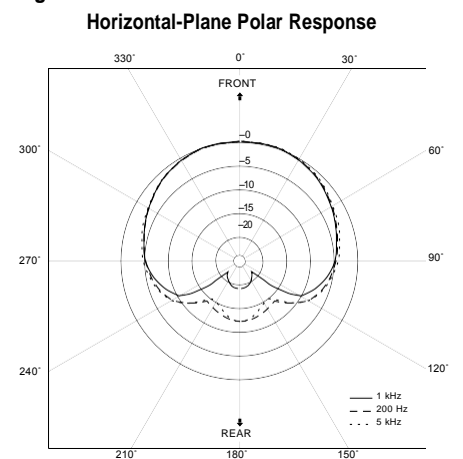

Fig. 3

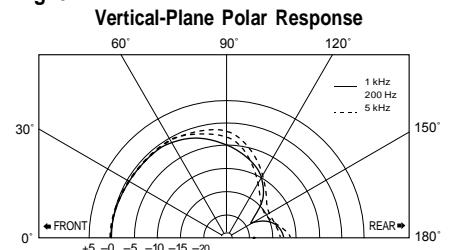
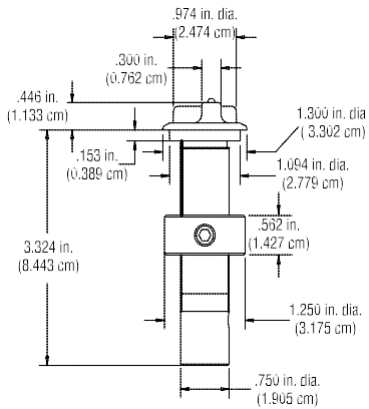
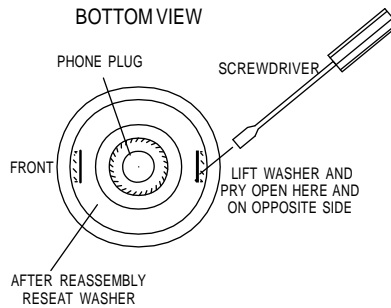

Fig. 4



1. Drill a 1.125 in. (2.858 cm) diameter hole for each mic.
2. Insert the mic tube through the hole. Orient the mic so the readable label faces the user.
3. Under the table, or behind the ceiling or wall panel, slide the ring over the tube and tighten the set screw.
4. Plug a mic cable with a female 3-pin XLR-type connector into the mic. Connect the other end of the cable to a phantom power supply. Or, if your mixer has phantom power, connect the

Fig.5



mic cable directly to a mic input and turn on phantom power.

#### Architects' and Engineers' Specifications

The microphone shall be the AKG/Crown model MB3 or equivalent. The microphone shall be a half-supercardioid electret condenser type. The microphone shall use the principle of phase coherency achieved by mounting a small-diameter element very near a boundary. This eliminates comb filtering in the audible spectrum.

The microphone will exhibit excellent off-axis response and gain-before-feedback. The mic shall have a bottom-mounted 3-pin pro audio XLR-type male connector. Powering shall be by 12-48V phantom power.

Nominal sensitivity shall be 22 mV/Pa. Maximum SPL shall be 120 dB SPL for 3% THD. Equivalent noise shall be 22 dBA nominal. Frequency response shall be 50 Hz to 15 kHz with a uniform off-axis response, about 20 dB down at the rear nulls.

The AKG/Crown model MB3 is specified.

#### Warranty

AKG/Crown professional microphone products are guaranteed unconditionally against malfunction from any cause for a period of three years from date of original purchase. See enclosed warranty sheet for additional information.

#### Service

If the microphone does not function properly, check that it is aimed correctly and is connected as described in this data sheet. If there is hum or no signal, first repair or replace the cable.

If you determine that the microphone product is defective, return the complete product in its original packaging to one of the addresses below. For further assistance or technical support call the international helpdesk at

**+43 676 83200 888.**

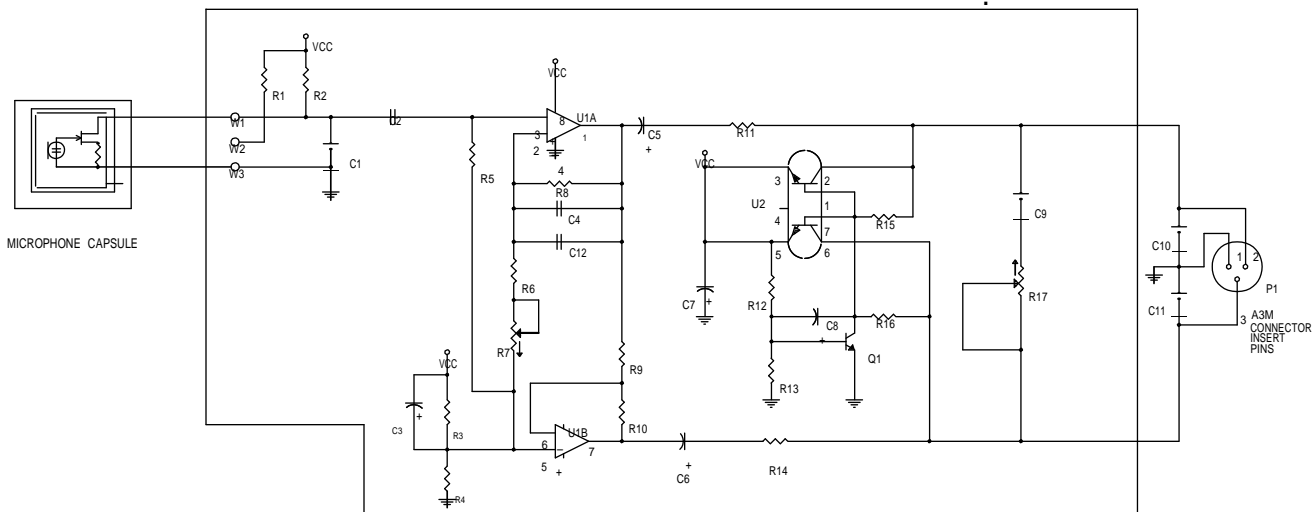

MB3 Schematic

MICROPHONE ELECTRONICS



**AKG ACOUSTICS GMBH** LAXENBURGER STRASSE 254, 1230 VIENNA/AUSTRIA  
**AKG ACOUSTICS, U.S. SERVICE** 24950 GROVE VIEW ROAD, MORENO VALLEY, CA 92551, U.S.A

© 2015 HARMAN International Industries, Incorporated. All rights reserved. AKG is a trademark of AKG Acoustics GmbH, registered in the United States and/or other countries.

Features, specifications and appearance are subject to change without notice.